

## Specification Guide

# mFurnace™

## Manufactured Home Electric Furnace



<b>Contents</b>	<b>Page</b>
Nomenclature.....	2
Features.....	4
Physical Data .....	4
Blower Performance.....	5
Dimensions .....	6
Wiring Diagram .....	6
Thermostat Connections .....	7
Electrical Data.....	9



Product improvement is a continuous process at Advanced Distributor Products. Therefore, product specifications are subject to change without notice and without obligation on our part. Please contact your ADP representative or distributor to verify details.

© 2025 by Advanced Distributor Products. All rights reserved.

# Furnace Nomenclature

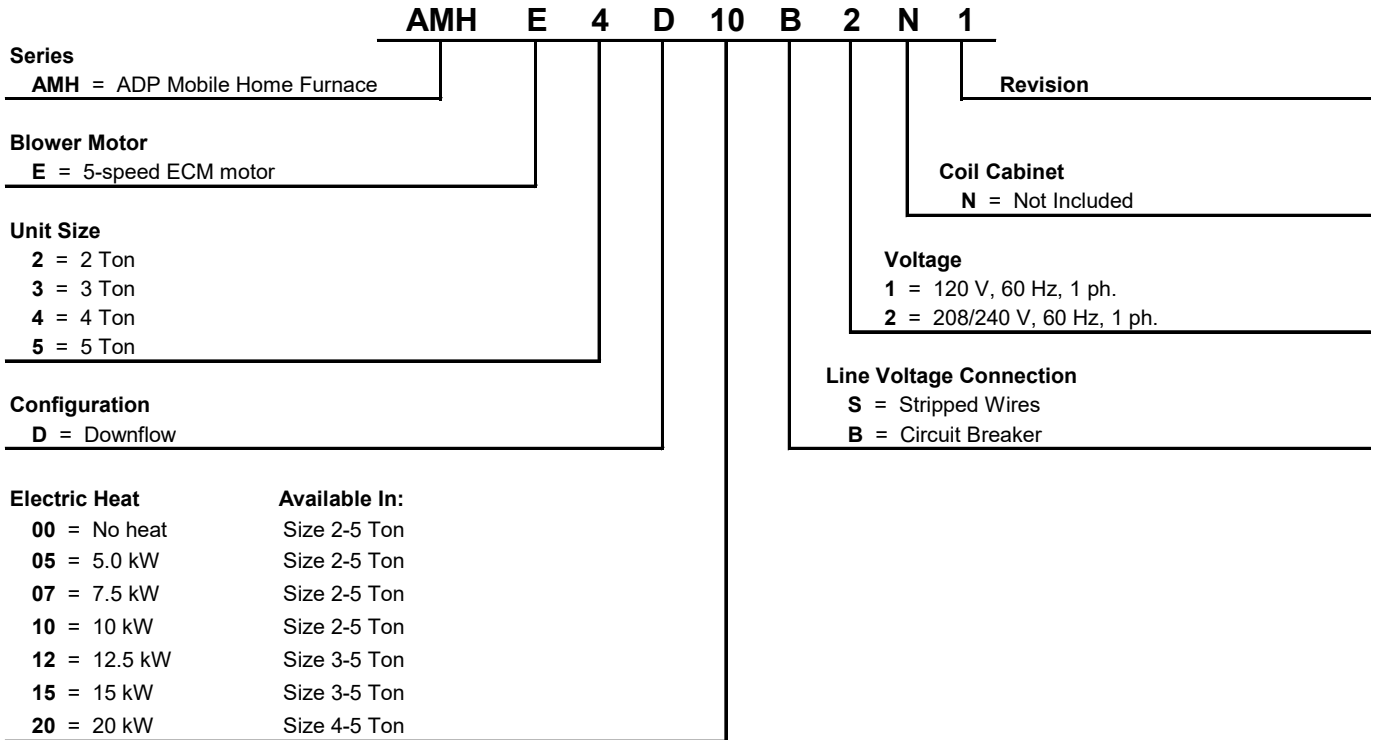

# Coil Cabinet Nomenclature

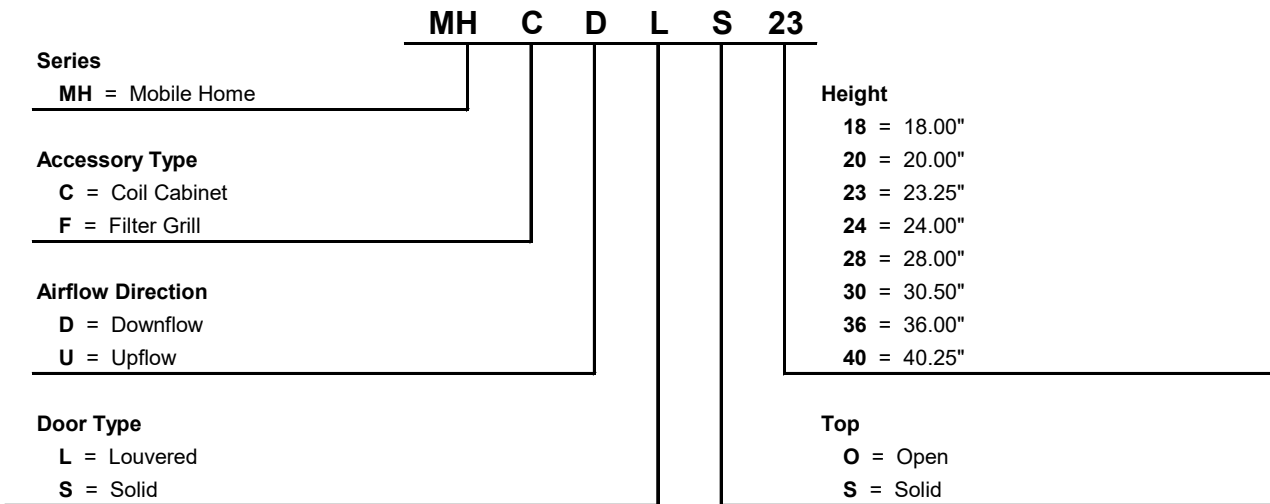

Coil Cabinet Model	Accessory Type	Airflow Direction	Door Type	Top	Height (in)	Depth (in)	Width (in)
MHCDLS23	Coil Cabinet	Downflow	Louvered	Solid	23.0	23.5	19.8
MHCDSO23	Coil Cabinet	Downflow	Solid	Open	23.0	23.5	19.8
MHCDLO23	Coil Cabinet	Downflow	Louvered	Open	23.0	23.5	19.8
MHCDLS30	Coil Cabinet	Downflow	Louvered	Solid	30.0	23.5	19.8
MHCDSO30	Coil Cabinet	Downflow	Solid	Open	30.0	23.5	19.8
MHCDLO30	Coil Cabinet	Downflow	Louvered	Open	30.0	23.5	19.8
MHCDLS40	Coil Cabinet	Downflow	Louvered	Solid	40.0	23.5	19.8
MHCDSO40	Coil Cabinet	Downflow	Solid	Open	40.0	23.5	19.8
MHFDLO18	Filter Grille	Downflow	Louvered	Open	18.0	N/A	19.8
MHFDLO24	Filter Grille	Downflow	Louvered	Open	24.0	N/A	19.8
MHCUSO20	Coil Cabinet	Up-flow	Solid	Open	20.0	23.5	19.8
MHCUSO24	Coil Cabinet	Up-flow	Solid	Open	24.0	23.5	19.8
MHCUSO28	Coil Cabinet	Up-flow	Solid	Open	28.0	23.5	19.8
MHCUSO36	Coil Cabinet	Up-flow	Solid	Open	36.0	23.5	19.8



**Filter Grille**



**Coil Door with Open Top**



**Louvered Door with Solid Top**



**Louvered Door with Open Top**



**UpFlow**

## Application Features

- Standard footprint for installation in manufactured homes.
- Compatible with 2-5 Ton AC or HP systems.
- Factory configured for downflow, field convertible for up-flow.
- Electric heat available factory or field installed for 208/240 V models.
- Multiple coil cabinet and filter grille options available.
- Perfectly matches with ADP manufactured housing coils.
- Meets UL 60335-2-40 product requirements.

## Cabinet Features

- Blower panel with handle and push-to-lock feature for easy access.
- Cabinet and door lined with high quality 5/8" foil faced insulation for quiet operation.
- Cabinet constructed of heavy-gauge, corrosion-resistant galvanized steel.
- Slide-out blower assemblies for easy access to blower motor.

## Electrical Features

- 120 V or 208/240 V 60 Hz supply voltages available.
- 5-speed high-efficiency ECM motor.
- Terminal board with screw down connections for thermostat wiring.
- Fan time delay built-in (1 second on, 45 seconds off).
- Multiple knockout options for line voltage and thermostat connections.
- Blower door safety switch on all models.

## Physical Data

		Model			
		AMHE2D*	AMHE3D*	AMHE4D*	AMHE5D*
<b>Nominal CFM Range</b>		600 - 800	900 - 1100	1200 - 1400	1200 - 1800
<b>Available Voltage<sup>[1]</sup></b>		(120 V, 60 Hz, 1 Ph), (208/240 V, 60 Hz, 1 Ph)			
<b>Maximum Electric Heat Available (kW)</b>		10	15	20	20
<b>Transformer Size and Type</b>		40 VA, Class 2			
<b>Blower Data</b>	<b>Motor H.P.</b>	1/3	1/2	3/4	3/4
<b>5-Speed High Efficiency ECM Motor (120 V)</b>	<b>F.L.A @ 120 V</b>	3.9	5.8	8.7	8.7
	<b>Wheel (Diameter x Width)</b>	10 x 9	10 x 9	10 x 9	11 x 9
<b>Blower Data</b>	<b>Motor H.P.</b>	1/3	1/2	3/4	3/4
<b>5-Speed High Efficiency ECM Motor (240 V)</b>	<b>F.L.A @ 240 V</b>	2.6	3.9	5.8	5.8
	<b>Wheel (Diameter x Width)</b>	10 x 9	10 x 9	10 x 9	11 x 9
<b>Approx. Weight lbs (base unit w/o electric heat)</b>		85	85	85	100

## Blower Performance

Unit Size	Tap	Airflow (CFM) vs. External Static Pressure (inches H <sub>2</sub> O)									
		0.1	0.2	0.3	0.4	0.5	0.6	0.7	0.8	0.9	1.0
<b>AMHE2D*</b>	1	368	317	244	196	197	196	196	197	196	196
	2	522	470	433	379	339	339	340	260	261	260
	3	711	675	634	604	565	525	493	449	450	449
	4 <sup>#</sup>	837	801	774	738	705	676	645	614	607	605
	5*	921	886	862	827	794	770	739	713	709	654
<b>AMHE3D*</b>	1	414	344	268	202	202	201	201	201	202	202
	2	760	701	659	613	568	522	486	447	447	446
	3	1063	956	916	873	840	803	767	735	720	672
	4 <sup>#</sup>	1157	1060	1005	963	926	900	867	840	807	805
	5*	1213	1142	1078	1035	997	961	936	905	881	848
<b>AMHE4D*</b>	1	486	408	333	253	216	216	216	216	216	216
	2	1046	1010	969	877	824	780	734	690	655	615
	3	1382	1347	1313	1286	1244	1194	1119	1068	1034	993
	4 <sup>#</sup>	1426	1389	1353	1318	1289	1241	1179	1111	1068	1034
	5*	1501	1474	1443	1411	1377	1339	1304	1243	1178	1134
<b>AMHE5D*</b>	1	858	798	731	661	596	536	492	450	449	449
	2	1053	1015	962	904	848	790	738	693	643	639
	3	1202	1160	1116	1068	1013	965	911	861	818	810
	4 <sup>#</sup>	1343	1318	1281	1240	1196	1160	1106	1060	1014	1008
	5*	1826	1799	1790	1761	1722	1677	1640	1594	1544	1494

### Notes :

1. All data is given while air handler is operating with a dry coil and air filter installed.
2. Speeds marked **\*bold with asterisk** are the factory speed settings for Cooling.
3. Speeds marked <sup>#</sup>**bold with asterisk** are the factory speed settings for Heating.
4. Heating speeds should not be reduced below factory setting.
5. Different speeds can be set for cooling mode; see installation instructions for changing cooling speeds.

# Dimensions

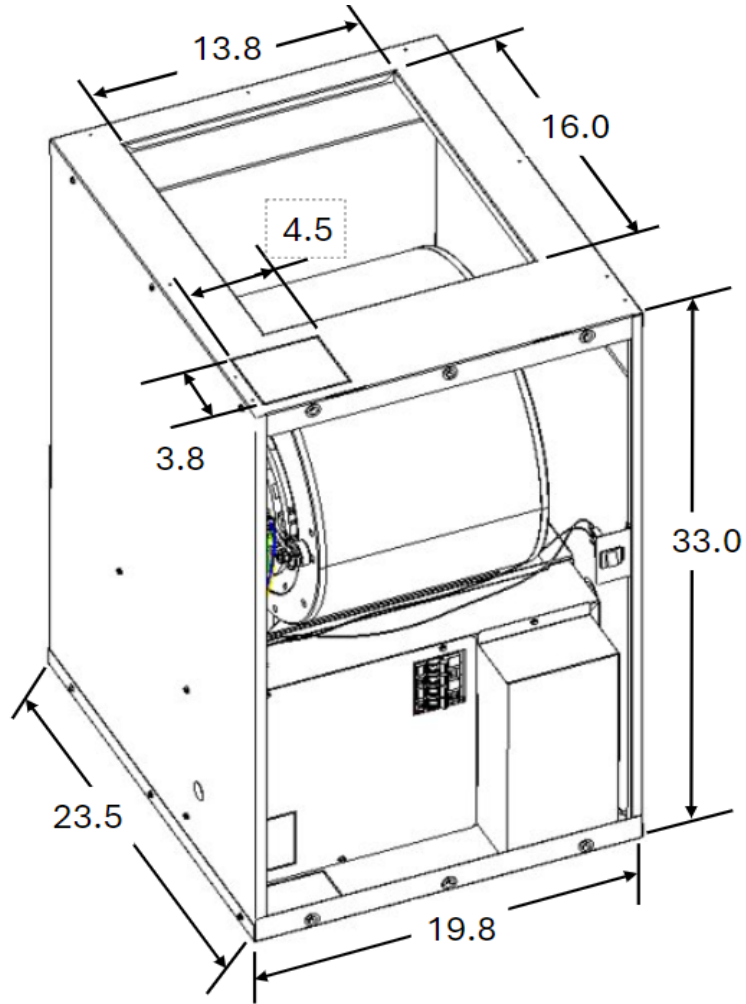

# Wiring Diagram

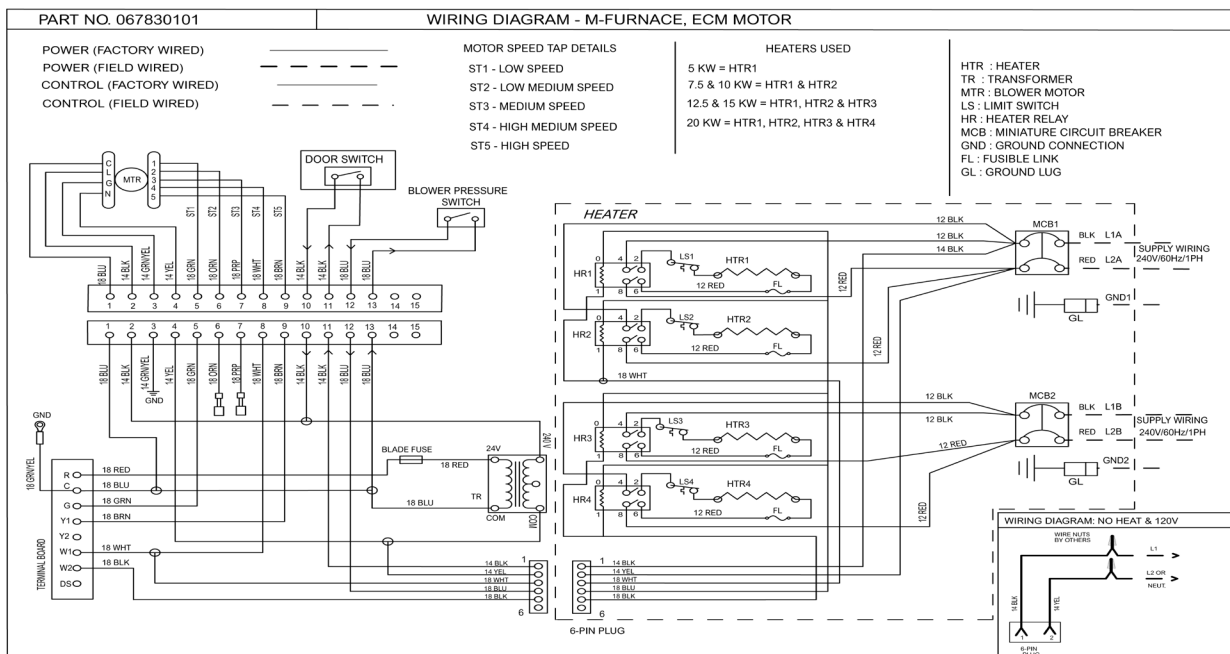

# Thermostat Connections

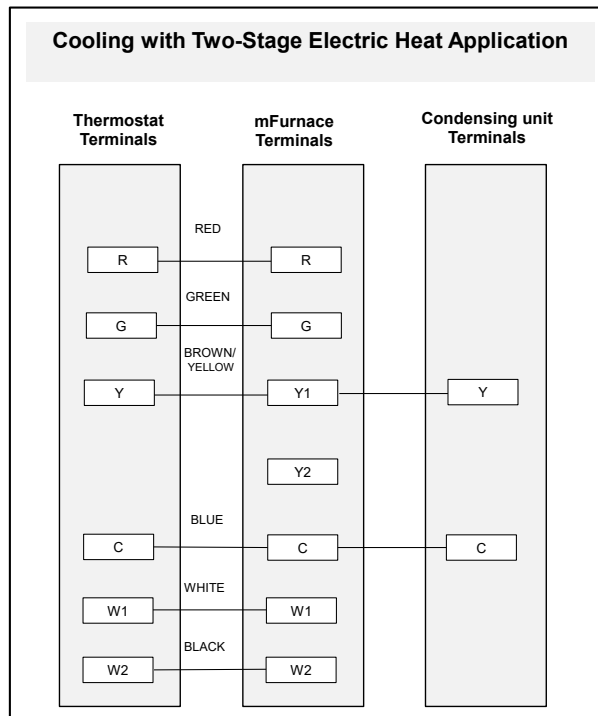
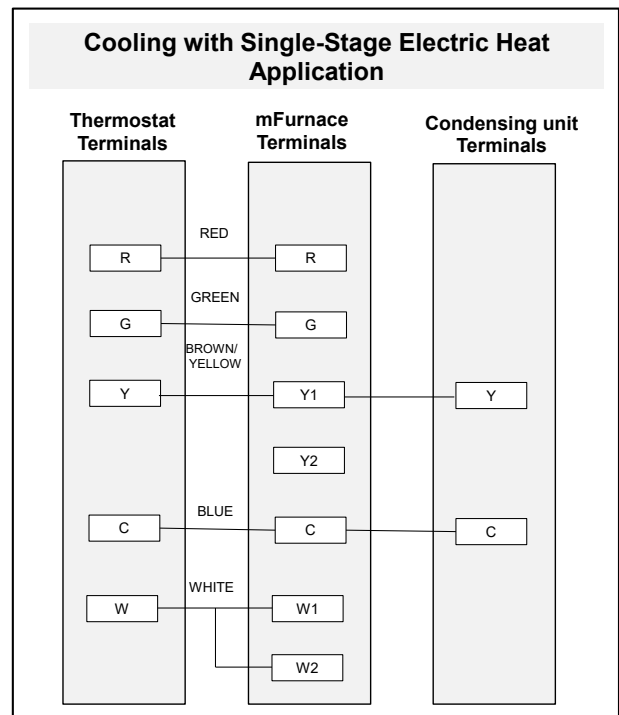
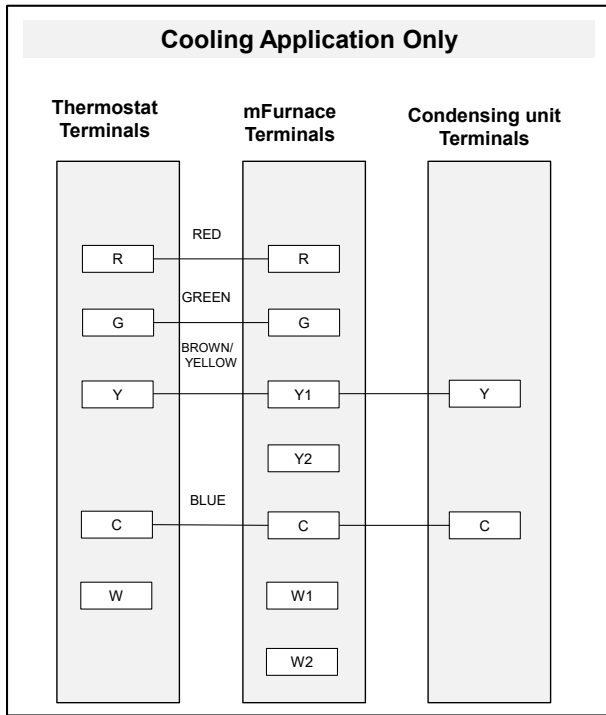

# Thermostat Connections

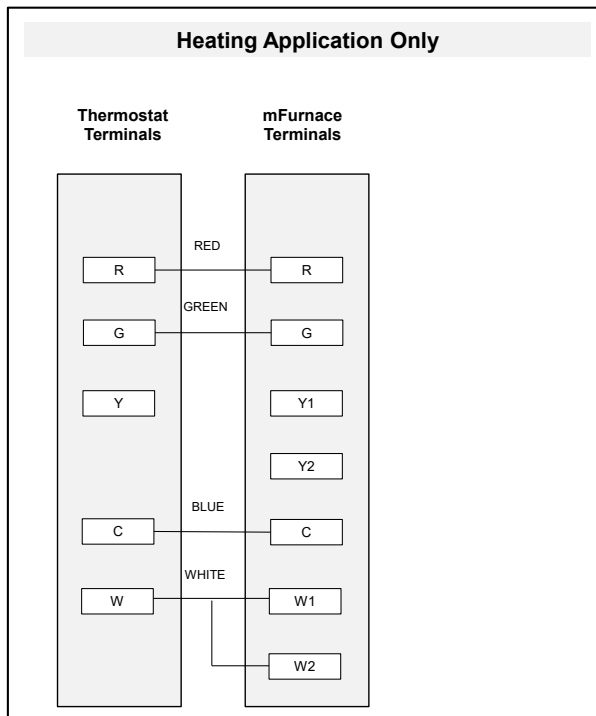
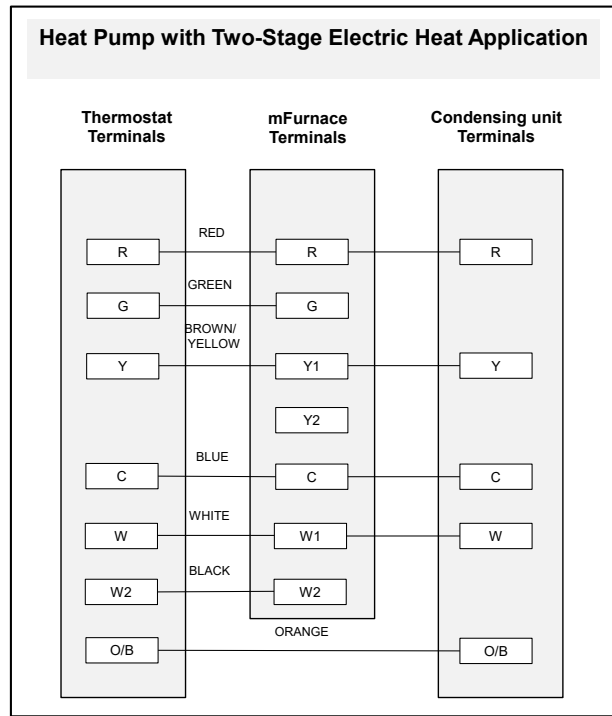
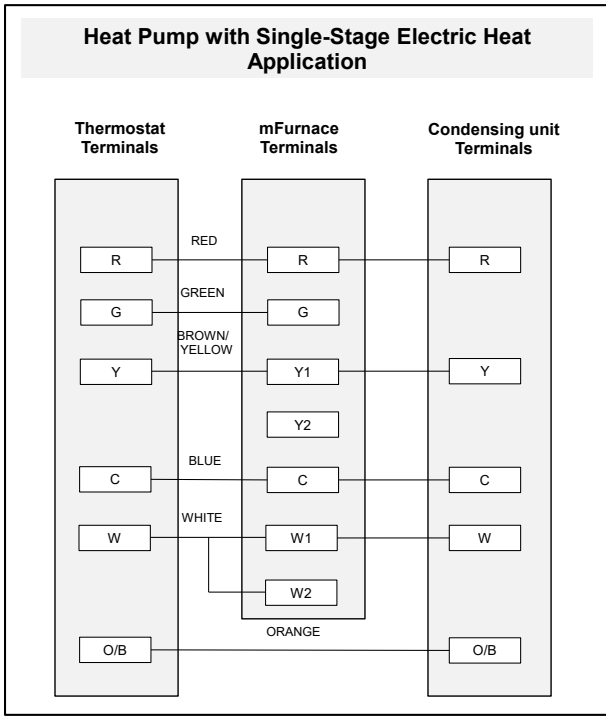



## Electrical Data: 120 V, ECM Motor, No Electric Heat

Unit Size	Total Heat Capacity	Heating Capacity		Circuit	Blower Amps (A)	Total Current, (A)	Minimum Circuit Ampacity (A)	Maximum Circuit Breaker
		kW	BTUH					
		240 V	240 V					
2	0	0	0	1	3.90	3.90	4.9	15
3	0	0	0	1	5.80	5.80	7.3	15
4	0	0	0	1	8.70	8.70	10.9	15
5	0	0	0	1	8.70	8.70	10.9	15

## Electrical Data: 240 V, ECM Motor, No Electric Heat

Unit Size	Total Heat Capacity	Heating Capacity		Circuit	Blower Amps (A)		Total Current, (A)		Minimum Circuit Ampacity (A)		Maximum Circuit Breaker size <sup>[2]</sup> (A)	
		kW	BTUH		208 V	240 V	208 V	240 V	208 V	240 V	208 V	240 V
		240 V <sup>[1]</sup>	240 V <sup>[1]</sup>									
2	0	0	0	1	2.70	2.60	2.7	2.6	3.4	3.3	15	15
3	0	0	0	1	3.90	3.90	3.9	3.9	4.9	4.9	15	15
4 & 5	0	0	0	1	6.00	5.80	6.0	5.8	7.5	7.3	15	15

## Electrical Data: 240 V, ECM Motor, Electric Heat

Unit Size	Total Heat Capacity	Heating Capacity		Circuit	Blower Amps (A)		Total Current, (A)		Minimum Circuit Ampacity (A)		Maximum Circuit Breaker size <sup>[2]</sup> (A)	
		kW	BTUH		208 V	240 V	208 V	240 V	208 V	240 V	208 V	240 V
		240 V <sup>[1]</sup>	240 V <sup>[1]</sup>									
2	5	5	17061	1	2.70	2.60	20.8	23.4	25.9	29.3	30	30
	7.5	7.5	25591	1	2.70	2.60	29.8	33.9	37.2	42.3	40	45
	10	10	34121	1	2.70	2.60	38.8	44.3	48.5	55.3	50	60
3	5	5	17061	1	3.90	3.90	22.0	24.7	27.4	30.9	30	35
	7.5	7.5	25591	1	3.90	3.90	31.0	35.2	38.7	43.9	40	45
	10	10	34121	1	3.90	3.90	40.0	45.6	50.0	57.0	50	60
	12.5	8.3	28321	1	3.90	3.90	33.9	38.5	42.3	48.1	45	50
		4.2	14331	2	0.00	0.00	15.2	17.5	19.0	21.9	20	25
	15	10	34121	1	3.90	3.90	40.0	45.6	50.0	57.0	50	60
5		17061	2	0.00	0.00	18.1	20.8	22.6	26.0	25	30	
4 & 5	5	5	17061	1	6.00	5.80	24.1	26.6	30.1	33.3	35	35
	7.5	7.5	25591	1	6.00	5.80	33.1	37.1	41.4	46.3	45	50
	10	10	34121	1	6.00	5.80	42.1	47.5	52.6	59.3	60	60
	12.5	8.3	28321	1	6.00	5.80	36.0	40.4	45.0	50.5	45	60
		4.2	14331	2	0.00	0.00	15.2	17.5	19.0	21.9	20	25
	15	10	34121	1	6.00	5.80	42.1	47.5	52.6	59.3	60	60
		5	17061	2	0.00	0.00	18.1	20.8	22.6	26.0	25	30
	20	10	34121	1	6.00	5.80	42.1	47.5	52.6	59.3	60	60
		10	34121	2	0.00	0.00	36.1	41.7	45.1	52.1	50	60

[1] For 208 volt use 0.751 correction factor for kW & BTUH.

[2] Breaker supplied with heat kit may need to be changed. Verify breaker sizing based on min, circuit ampacity.