



Installation Instructions

Downflow Coil

TABLE OF CONTENTS	PAGE
General	1
Downflow Application	2
Refrigerant Line Installation	3
Refrigerant Charging.....	3
Condensate Drain	4
Coil Cleaning.....	5
Metering Device	6
Warranty	8
Installation Check List.....	8



GENERAL

ADP evaporator coils are designed for use with AC condensing units or heat pump units. These instructions are intended as a general guide and do not supersede local codes in any way. Consult with local authorities having jurisdiction before installation. **Read this installation manual and all safety messages prior to installing the evaporator coil.**

Check coil for shipping damage and verify the contents of the box containing the evaporator coil. If you should find damage, immediately contact the last carrier. Verify the efficiency performance requirements, such as SEER, EER, and/or HSPF, are appropriate with the matched condensing or heat pump units. Check outdoor unit manufacturer for proper line sizing. **Coils are shipped with a 10 psi dry air holding charge. Puncture rubber plug on suction line to release charge before removing plugs.** The absence of pressure does not verify a leak. Check the coil for leaks before installing or returning it to your wholesaler.

Position the coil on the outlet of the furnace using sheet metal screws. In horizontal installations, the coil should be pitched approximately 1/2" toward the drain connections. **NOTE:** Sloping over 5/8" may cause blow off into the auxiliary drain hole in high static situations. Drain pans are made of a polymer that can withstand temperatures up to 450°F.

SAFETY CONSIDERATIONS

Your safety and the safety of others are very important.

We have provided many important safety messages in this manual and on your appliance. Always read and obey all safety messages.



This is the safety alert symbol.

This symbol alerts you to potential hazards that can kill or hurt you and others.

All safety messages will follow the safety alert symbol and signal word. These signals words mean the following:

DANGER: You can be **killed or seriously injured** if you don't immediately follow instructions.

WARNING: Indicate a potentially hazardous situation which, if not avoided, could result in **death or serious injury**.

CAUTION: Indicates a potentially hazardous situation which, if not avoided, may result in **minor or moderate injury**. Caution may also be used to alert against unsafe practices.

NOTICE: Indicates a statement of company policy as the message relates directly or indirectly to the safety of personnel or protection of property.

IMPORTANT: More detailed information concerning the statement of company policy as the message relates directly or indirectly to the safety of personnel or protection of property.

All safety messages will tell you what the potential hazard is, tell you how to reduce the chance of injury, and tell you what can happen if the instructions are not followed.



** Note: Large tonnage coils (greater than 5 tons) are not AHRI certified and do not have Microban® protection.



Product improvement is a continuous process at Advanced Distributor Products. Therefore, product specifications are subject to change without notice and without obligation on our part. Please contact your ADP representative or distributor for details.

© 2025 by Advanced Distributor Products. All rights reserved.

DOWNFLOW APPLICATION

Downflow drain pans have drain connections on the right and left front side of the evaporator coil. Refer to Specification Guide for limitations. Maximum CFM airflow is labeled on each coil.

1. **Lower plenum through floor opening** - Align the base of the unit with the matching plenum, then lower the unit over the plenum. The coil cabinet must be level or sloped slightly toward the drain outlet and secured and sealed to the plenum.
2. **Fitting** - Set the furnace on top of the coil case. Make sure to check that the back side of the discharge opening is snug up against the duct flange at the top rear of the coil case.
3. **Sealing** - Installers can optionally field install coil brackets on the coil. Align the brackets with the rear and sides of the coil cabinet. See figure 2 illustrating how the furnace, coil, and coil locator brackets fit together. Seal between the furnace cabinet and the coil cabinet with foil tape to prevent air leaks.

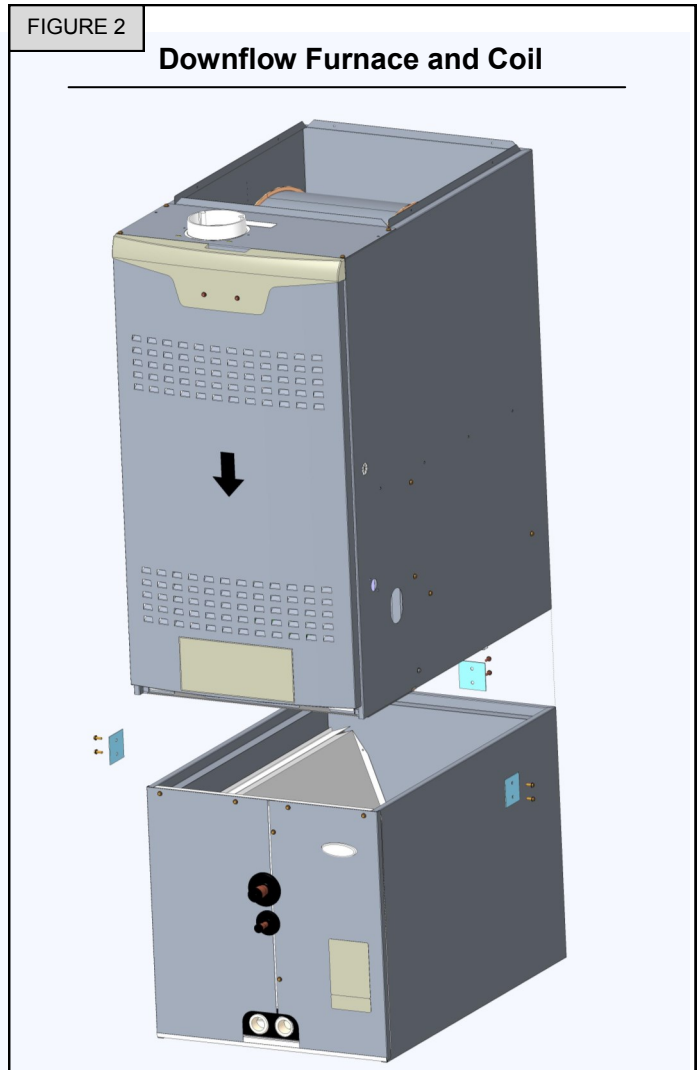
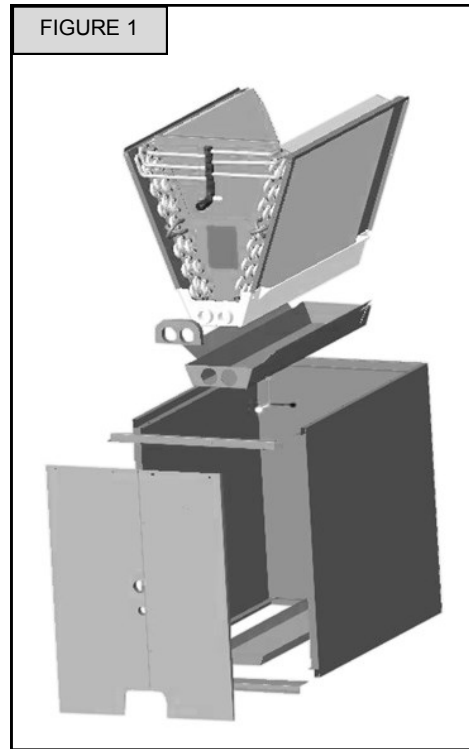

REFRIGERANT LINE INSTALLATION

ADP recommends installing a filter drier and sight glass in the liquid line. While brazing, purge the system with Nitrogen to prevent contamination. ADP recommends reattaching and insulating the TXV sensing bulb at a 10 to 2 o'clock position on the suction line, outside the coil housing, no more than one

foot from the connection. Evacuate the system to 500 microns to ensure proper air and moisture removal (**Note: Deep evacuation or triple evacuation method recommended**). Open the suction service valve slowly and allow the refrigerant to bleed into the system before opening the liquid service valve.

REFRIGERANT CHARGING INSTRUCTIONS ¹

When charging in cooling mode, the outdoor temperature should be 60°F or higher. To allow the pressures to stabilize, operate the system a minimum of 15 minutes between adjustments. When adjusting charge to systems with micro-channel outdoor coils, make small (1 ounce or less) adjustments as these systems are very sensitive to refrigerant charge.

TXV Charging^{2, 3, 4} – Use the charging method recommended by the outdoor unit instructions. Alternatively, ADP recommends charging to 12°F sub-cooling for AC units and 10°F sub-cooling for heat pump units. In addition, if equipped with an adjustable valve, adjust to 10°F superheat.

Fixed Orifice Charging^{2, 3, 4} – Use the superheat recommended by the outdoor unit instructions. Alternatively, ADP recommends charging to the superheat table below.

Outdoor Air Temp. (°F)	60	65	70	75	80	85	90	95	100	105	110	115
Superheat (°F)	31	28	25	22	20	16	13	10	8	6	5	5

For heat pump units initially charged in the cooling mode, final adjustments to charge in the heating mode are acceptable if necessary. Some heat pump units require charging in the heating mode. In this case, refer to the outdoor instructions for recommended charging procedures.

If the system is undercharged after the initial charge, add refrigerant until the sight glass is clear and recommended pressures, temperatures, sub-cooling and superheat can be obtained. If the system is overcharged after the initial charge, recover refrigerant until recommended pressures, temperatures, sub-cooling and superheat can be obtained.

Notes:

1. If any problems or questions regarding charge occur, contact customer service.
2. OEM charging methods vary depending on design and application. Verify all recommended pressures, temperatures, sub-cooling and superheat settings result in the proper charge.
3. ADP coils may require charge compensation due to size variation versus the OEM coil.
4. Temperatures are $\pm 2^\circ\text{F}$ unless otherwise recommended.

CONDENSATE DRAIN

Coils are equipped with a drain connection. Drain plugs are provided; remove and discard the plug with ½" drive ratchet and verify that remaining plugs are tight (2.5 ft-lbs). Attach drain line to pan with ¾" male pipe thread PVC fittings. Hand tight is adequate – **do not over tighten & do not reduce drain line size!**

Route drain line so it will not be exposed to freezing temperatures and do not interfere with accessibility to the coil, air handling system or filter. The drain should be pitched downward 1" per 10' with a 2" trap as close to the coil as possible. If line makes a second trap, or has an extended run before termination, a vent tee should be installed after the trap closest to the pan. See Figure 9.

If the coil is located in or above a living space where damage may result from condensate overflow, a separate ¾" drain must be provided from the secondary drain connection. Run this drain to a place in compliance with local installation codes where it will be noticed when unit is operational. Condensate flowing from the secondary drain indicates a plugged primary drain. Prime the trap with water. Test line for leaks. Test water flow with unit in operation. An auxiliary drain pan should be installed under the unit, and have a larger footprint than the coil, as specified by most local building codes.

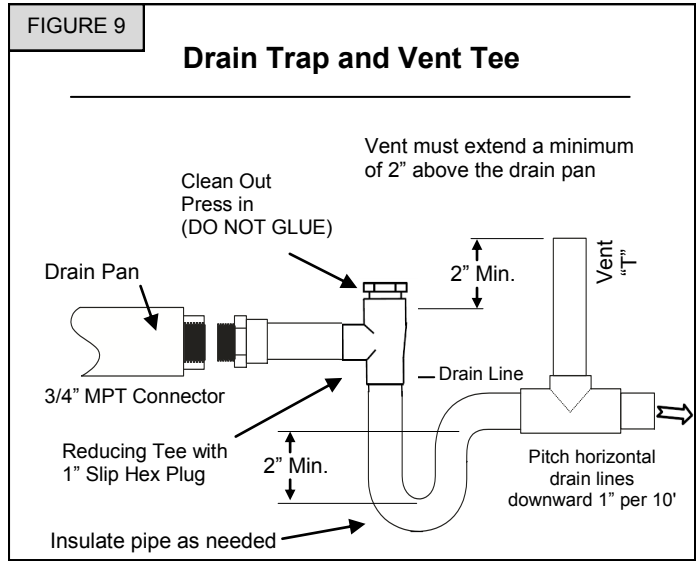

! IMPORTANT !

The Clean Air Act of 1990 bans the intentional venting of refrigerant (CFC's and HFC's). Approved methods of reclaiming must be followed. Fines and/or incarceration may be levied for non-compliance.

COIL CLEANING

The coils should be inspected and preferably cleaned before installation, and a minimum of once a year or more often, if necessary. Cleaning of the indoor unit's coil should be performed by a licensed professional service technician (or equivalent).

1. Put on personal protective equipment – Safety glasses and/or face shield, waterproof clothing and gloves.
2. Vacuum or brush the coil to remove any matted or surface foreign debris from the fins (dirt, animal hair, etc).
3. Only clean potable water should be used to clean the coils. Clean coil slab surfaces by spraying steady and uniformly at a vertical angle of 30 to 45 degrees with a constant stream of water at moderate pressure (**less than**

50 psig) from top to bottom. A fan nozzle will work best. Do not spray the coil from a horizontal direction.

4. Use of acidic (below 5) or alkaline (above 9) cleaners can strip off factory protective coatings and reduce the life of an aluminum coil.
5. Alkaline (also called no-acid) coil cleaners are products that has a pH greater than 7. Acid coil cleaners are products that have a pH less than 7.

Note: Attempting to back flush from the inside of the coil will require removing parts from the unit, and it may be very difficult to flush the whole coil surface. Attempting to blow water through a coil will slow the water stream and reduce the *flushing action of the outer fin surface*.

METERING DEVICE

Coils are suited for R-22 and R-410A refrigerants and can be used with a piston or a TXV. Replacement TXV part numbers are listed below; see kit instructions for change out or installation. ADP recommends placing a wet rag around the suction line at the cabinet during brazing to prevent overheating and damaging the sensing bulb.

For optimum performance, reattach and insulate the bulb at a 10 to 2 o'clock position outside of the cabinet to the main suction line no more than one foot from the suction line connection. If necessary, the bulb can be installed on a vertical suction line. In this instance, the bulb must be placed before any trap, with the bulb's capillary tube facing upward. When changing a system from AC to heat pump or heat pump to AC, check the current TXV specifications to determine if a TXV replacement is required. **If the evaporator coil contains a non-bleed TXV and is used with a condensing unit containing a reciprocating compressor, a hard start kit will be required on the condensing unit.**

Cased coils with a piston metering device are shipped with a cap and hex nut over the threaded fitting. Remove the cap and nut slowly, allowing charge to escape, and secure the liquid line stub (attached to cabinet) to the distributor assembly with hex nut. Discard cap.

For optimum performance, the piston should be sized to match the recommendation from the outdoor unit manufacturer. If the outdoor unit manufacturer does not recommend a piston size, refer to the piston size chart. When changing pistons, refer to Figure 10 and use the following procedure:

1. Loosen hex nut located on liquid line and separate from distributor assembly.
2. Remove the existing piston from inside the distributor assembly.
3. Insert the desired piston into the distributor assembly.
4. Inspect Teflon O-Ring and replace if damaged. Ensure Teflon O-Ring is in place.
5. Re-install hex nut to body and torque to 10 ft-lbs.

R-22 TXV Part Numbers	
18-36 MBTUH Bleed A/C	65540600
42-60 MBTUH Bleed A/C	65540700
18-36 MBTUH Non-Bleed A/C	99167501
42-60 MBTUH Non-Bleed A/C	99167502
18-36 MBTUH Non-Bleed A/C-HP	65616201
42-60 MBTUH Non-Bleed A/C-HP	65616202

R-410A TXV Part Numbers	
18-36 MBTUH Non-Bleed A/C	65026401
42-60 MBTUH Non-Bleed A/C	65026400
18-36 MBTUH Non-Bleed A/C-HP	65616601
42-60 MBTUH Non-Bleed A/C-HP	65616602
18-36 MBTUH Bleed A/C	67304001
42-60 MBTUH Bleed A/C	67304002
18-36 MBTUH Bleed A/C-HP	67304101
42-60 MBTUH Bleed A/C-HP	67304102

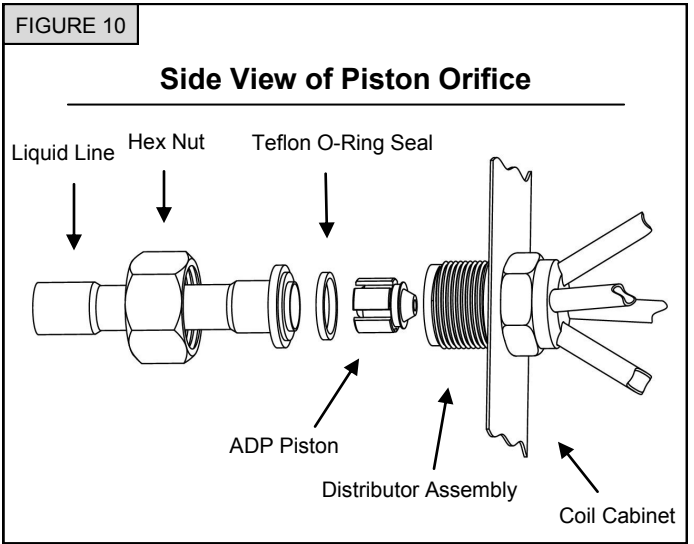

Piston Size				
Ton	R-22		R-410A	
	Piston Size	Part #	Piston Size	Part #
1	41	100000035	41	100000035
1.5	53	100000036	49	100000049
2	59	100000037	53	100000036
2.5	67	100000039	59	100000037
3	73	100000041	67	100000039
3.5	80	100000044	73	100000041
4	84	100000045	76	100000042
5	93	100000047	93	100000047

⚠ **IMPORTANT** ⚠

When changing the metering device, ensure the metering device matches the refrigerant type and capacity of the condensing unit. Failure to do so will result in poor performance and possible compressor damage. All coils must be matched properly as listed in the AHRI directory.



ADP LIMITED WARRANTY

Term of Warranty

Advanced Distributor Products (ADP) warrants that products sold shall be of merchantable quality, free of defects in material and workmanship, under normal use and service, for a period of five (5) years from the date of installation, **not** to exceed six (6) years from the date of manufacture subject to the terms of ADP's limited warranty.

For information on this product's warranty, including accessing complete warranty terms, registering for an extended warranty* or instructions on filing a warranty claim, please go to www.ADPwarranty.com.

** In such states or provinces where registration requirements are prohibited, failure to complete registration by the consumer does not diminish his or her warranty rights.*

Equipment Information

Please complete information below and retain this warranty for records and future reference.

Unit Model Number: _____

Serial Number: _____

Installing Contractor: _____

Installation Date: _____

Phone: _____

INSTALLATION CHECKLIST

Downflow:

- See coil label for max ft/min
- Tape top edge of insulation

Metering Device:

- Verify and/or install correct TXV or piston

TXV Installation Only:

- Place TXV bulb at 10 to 2 o'clock position
- Insulate bulb
- Connect equalizer line

Drains:

- If over a finished space, install secondary drain pan

Air Path:

- Cover any unused knockouts

Charging:

- Charge per charging instructions

