

Specification Guide

HH Series A1 Refrigerants

Evaporator Coils



Contents	Page
HH Series Horizontal Slab Coils	
Features & Nomenclature	2
Specifications.....	3



Product improvement is a continuous process at Advanced Distributor Products. Therefore, product specifications are subject to change without notice and without obligation on our part. Please contact your ADP representative or distributor to verify details.

© by Advanced Distributor Products. All rights reserved.

HH Series – Features & Nomenclature

Product Features

- High efficiency lanced fin design.
- “No-hassle” 5-year warranty. 10 year Limited Warranty available.
- R-22, R-410A, AC & Heat Pump compatible.
- All coils have durable packaging with bar coded labels on the box.
- Threaded expansion valves available factory installed or as a field installed kit.
- Coils are air pressure tested at 500 psi, leak tested with helium, sealed with rubber plugs, then charged with dry air.
- Piston options include externally accessible body for easy piston change out and/or TXV installation.
- Liquid line refrigerant connections are 3/8" ODF.
- Suction line refrigerant connections are 7/8" ODF.
- Microban® antimicrobial additive to inhibit the growth of mold and mildew in the drain pan.
- UV resistant drain pans are molded of high temperature (450° F) engineered polymer.
- Cased coil cabinets are fully lined with 5/8" foil faced insulation.
- Non-captive refrigerant lines with long stubs make for easy installation.
- Copper distributor tube assembly provides brass to brass threads for trouble-free service of TXV.
- Corrosion resistant coil header plates.

Nomenclature

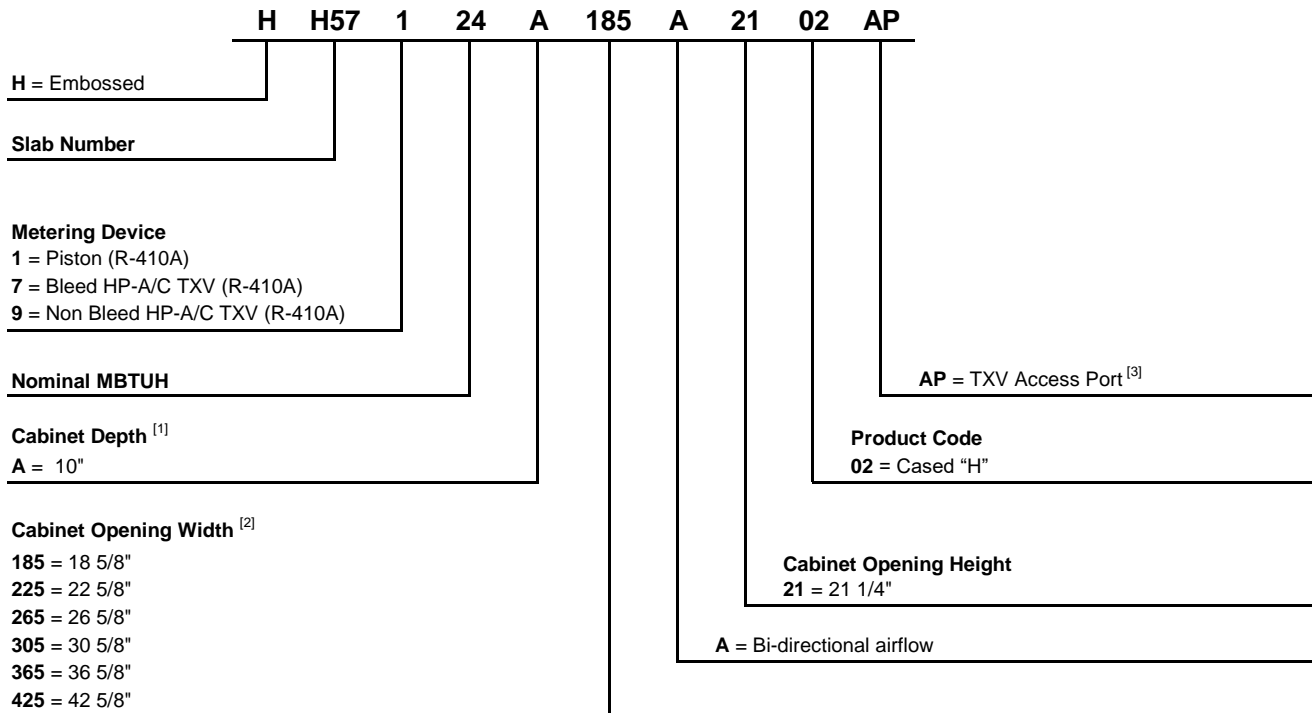

R-410A Pistons		
MBTUH		Size
12	=	41
18	=	49
24	=	53
30	=	59
36	=	67
42	=	73
48	=	76
60	=	93

[1] Depth is fixed, 10" is the only selectable option.

[2] Cabinet opening width is not a selectable option; see dimensions.

[3] Piston will always be sized to match the nominal BTU rating of the coil.

HH Series – Specifications

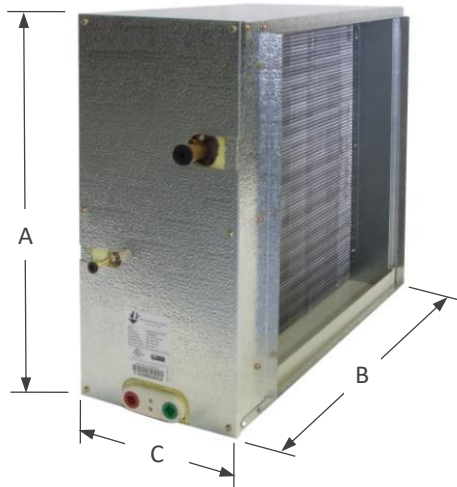

A = Height
 B = Width
 C = Depth (excluding flange)

Supply Opening: (A - 1.50") x (B - 4 3/8")
 Return Opening: (A - 1.50") x (B - 4 3/8")

Weight / Pallet Qty

Slab Num	Weight (lbs)	Pallet Quantity
H57	36	6
H58	41	4
H59	44	4
H60	50	4
H61	57	3
H62	61	3
H66	75	3

Dimensions

Slab Number	Nominal Tonnage	Overall			Supply/Return Opening	
		Height [A]	Width [B]	Depth [C]	Height	Width
H57	1.5 - 3	22 3/4"	23"	10"	21 1/4"	18 5/8"
H58	2 - 4	22 3/4"	27"	10"	21 1/4"	22 5/8"
H59	2.5 - 4	22 3/4"	31"	10"	21 1/4"	26 5/8"
H60	3 - 5	22 3/4"	35"	10"	21 1/4"	30 5/8"
H61	3.5 - 5	22 3/4"	41"	10"	21 1/4"	36 5/8"
H62, H66	3 - 5	22 3/4"	47"	10"	21 1/4"	42 5/8"

Airflow Data

Slab Number	Wet Coil Air Pressure Drop (Inches W.C.) by CFM							
	600	800	1000	1200	1400	1600	2000	2400
H57	.17	.19	.22	.25	-	-	-	-
H58	-	.18	.20	.22	.24	.26	-	-
H59	.05	.08	.11	.15	.19	.23	-	-
H60	-	-	-	.17	.18	.23	.27	-
H61	-	-	-	-	.19	.21	.25	-
H62	-	-	-	.15	.17	.19	.23	.27
H66	-	-	.08	.11	.14	.17	.23	.31



2140 Lake Park Blvd, Richardson, TX 75080
www.adpnow.com