

Specification Guide

Dedicated Downflow A1 Refrigerants Evaporator Coils



Contents	Page
Downflow Coils	
Features	2
Nomenclature	3
Specifications.....	4



Product improvement is a continuous process at Advanced Distributor Products. Therefore, product specifications are subject to change without notice and without obligation on our part. Please contact your ADP representative or distributor to verify details.
© by Advanced Distributor Products. All rights reserved.

Downflow Coil – Product Features

- High efficiency lanced fin design
- “No-hassle” 5 year warranty. 10 year Limited Warranty available.
- R-22, R-410A, AC & Heat Pump compatible.
- All coils have durable packaging with bar coded labels on the box.
- Threaded expansion valves available factory installed or as a field installed kit.
- Coils are air pressure tested at 500 psi, leak tested with helium, sealed with rubber plugs, then charged with dry air.
- Piston options include externally accessible body for easy piston change out and/or TXV installation.
- Microban® antimicrobial additive to inhibit the growth of mold and mildew in the drain pan.
- UV resistant drain pans are molded of high temperature (450 deg. F) engineered polymer.
- Copper refrigerant connections for easy brazing on both copper and aluminum slab models.
- Cased coil cabinets are fully lined with 5/8" foil faced insulation.
- Non-captive refrigerant lines with long stubs make for easy installation.
- Enhanced refrigerant pipe grommets: secure, tight, and easy to install.
- Copper distributor tube assembly provides brass to brass threads for trouble-free service of TXV.
- Expansion valve with improved temperature sensing:
 - Mounted inside cabinet to prevent external sweating
 - Bulb clamped standard factory installed
- Cabinet insulation hold down tabs for easy drain pan removal.
- Interlocking doors reduce air leakage and allow for easy access.
- Foam drain seal for reduced air leakage.
- Maximum CFM printed on the label of each coil.
- Suction line refrigerant connections are 3/4" ODF (A-Coil 18-36 size models) or 7/8" ODF (A-Coil 42-60 size models)
- Suction line refrigerant connections are 1.125".
- Corrosion resistant coil header plates.

Downflow Coil Nomenclature

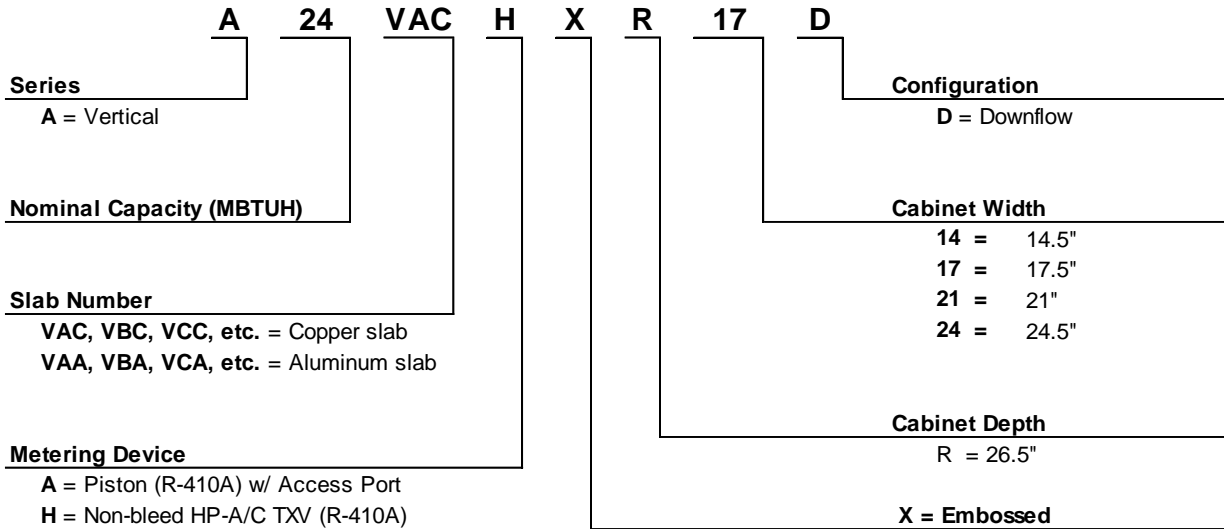

Downflow Coil – Cased Specifications

A = Width
B = Depth
C = Height

Supply Opening: (A - 1.5") x (B - 1.5")
Return Opening: (A - 1.0") x (B - 0.5")

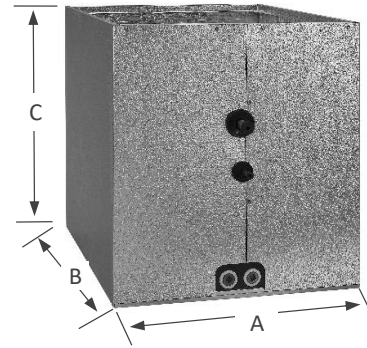

C = Copper slab; A = Aluminum slab.

Dimensions / Airflow Data

Slab Number	Nominal MBTUH	Width [A]	Depth [B]	Height [C]	Max CFM	Face Vel. [2] (fpm)	DRY Coil Air Pressure Drop (inches W.C.) by Coil Width [A]
VA (C,A)	18	14.5" - 17.5"	26.5"	18"	600	205	.05
	24				800	274	.14
VB (C,A)	18	14.5"			600	171	.06
	24	800			229	.14	
	17.5"	18			600	171	.06
		24			800	229	.14
		30			1000	286	.22
		36			1150	329	.27
VC (C,A)	14.5"	18			600	171	.02
		24			800	229	.10
	17.5"	18			600	171	.02
		24			800	229	.10
		30			1000	286	.18
		36			1200	343	.26
VD (C,A)	17.5"	24			800	196	.11
		30			1000	245	.19
		36			1200	294	.27
	21.0"	24			800	196	.05
		30		1000	245	.11	
		36		1200	294	.17	
VE (C,A)	17.5" - 21"	42		1350	331	.21	
		48		1000	190	.17	
		48		1200	229	.25	
	24.5"	42		1400	267	.30	
		48		1400	267	.21	
		48		1600	305	.28	
VF (C,A)	17.5" - 21"	36	1200	206	.17		
		42	1400	240	.23		
	24.5"	42	1400	240	.10		
		48	1600	274	.14		
VG (C,A)	21.0"	42	1400	218	.20		
		48	1600	249	.24		
		60	1850	288	.28		
	24.5"	42	1400	218	.07		
		48	1600	249	.11		
		60	1950	304	.18		
VH (C,A)	21.0"	42	1400	200	.20		
		48	1600	229	.26		
		60	1900	271	.32		
	24.5"	42	1400	200	.06		
		48	1600	229	.11		
		60	2000	286	.17		
VL (C,A)	24.5"	42	1400	200	.11		
		48	1600	229	.21		
		60	1950	286	.25		

Weights

		Copper	Aluminum
VA (C,A)		27	26
VB (C,A)		29	28
VC (C,A)		33	32
VD (C,A)		31	30
VE (C,A)		42	40
VF (C,A)		50	48
VG (C,A)		61	55
VH (C,A)		64	61
VL (C,A)		68	65
		67	64
		70	67
		70	67
		74	71
		75	72
		79	76
		84	81

Downflow Coil – Pallet Quantities

Cabinet Width	Pallet Qty by Cabinet Height (in)		
	18"	23.5"	27.5"
14.50"	8	8	4
17.50"	8	4	4
21.00"	2	2	2
24.50"	2	2	2



2140 Lake Park Blvd, Richardson, TX 75080
www.adpnow.com